

**PURE WELDING**

**SOLDADURA TUBULAR AUTOPROTEGIDA**

**FLUX CORED ARC WELDING (FCAW)**



DIÁMETRO  
0.035" (0.9mm)

**SELF-SHIELDED WIRE**  
Autoprotegida de acero inoxidable

**SWEISSCODE M3-313**

**SHIELD GAS**  
GAS DE PROTECCIÓN

**NO REQUIERE**

**ESPECIFICACIONES TÉCNICAS**

Tipo de alambre	<b>E308LT0-3</b>	Tipo de metal	<b>Acero inoxidable</b>	Norma	<b>AWS A5.20 - ASME SFA 5.20</b>
Peso	<b>0.9Kg - 2Lb</b>				

**POSICIONES DE SOLDADURA**

Uniones de filetes

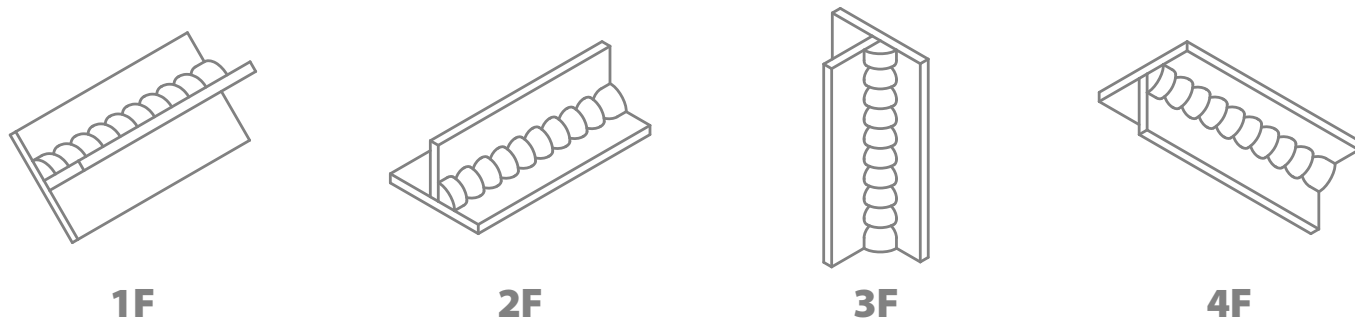

Uniones biseladas

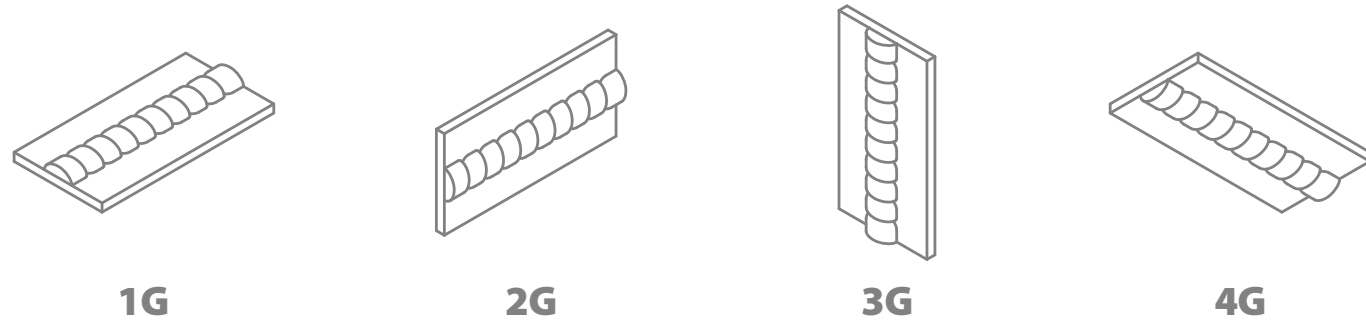

Uniones de tuberías

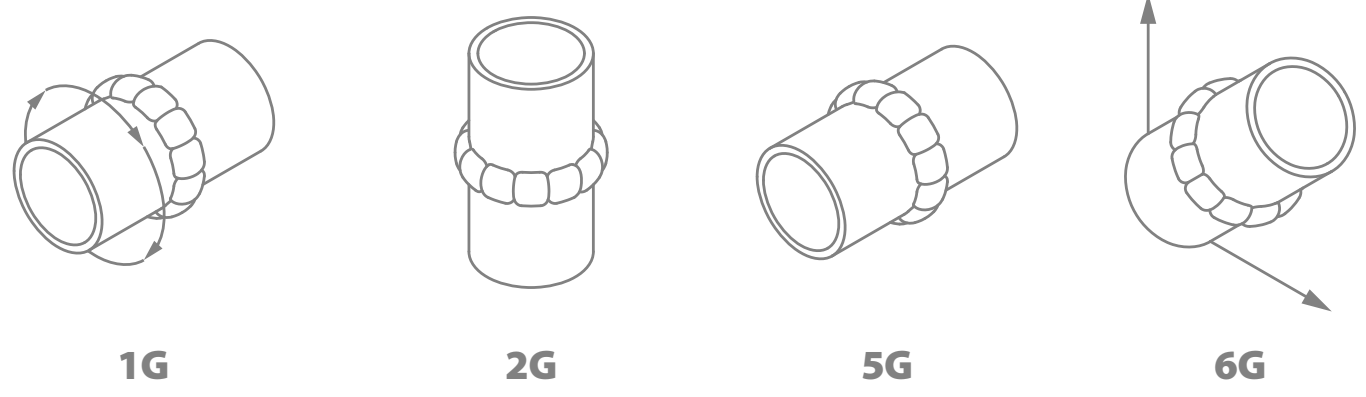

**ÁNGULO DE VIAJE**

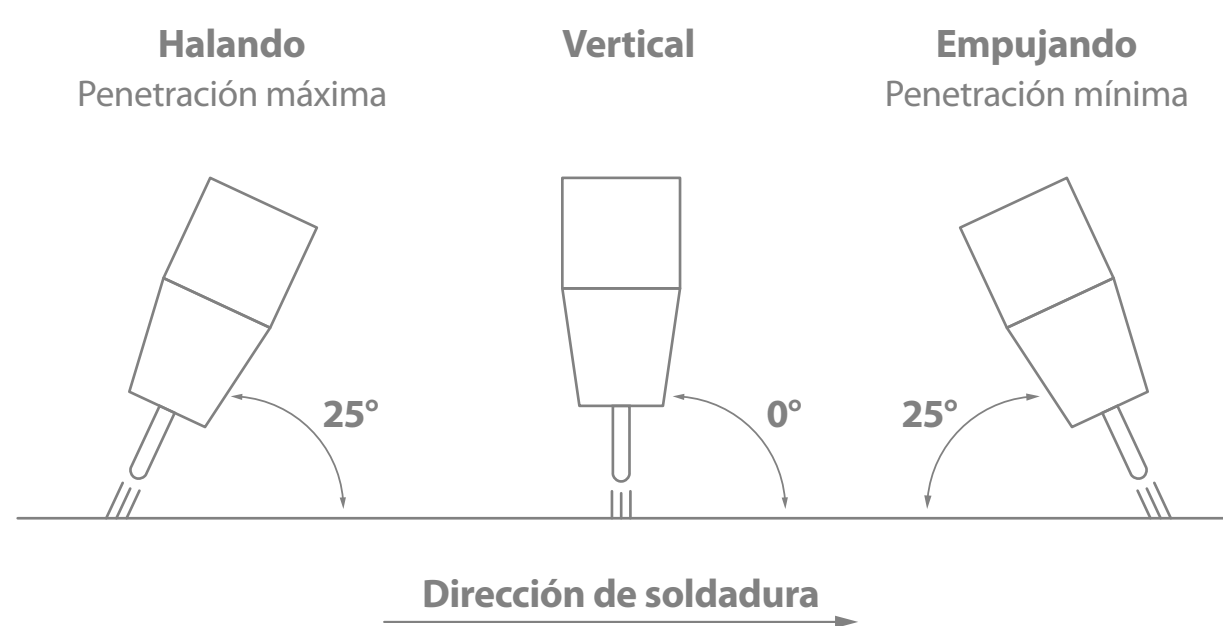

**TIPO DE RODILLO**

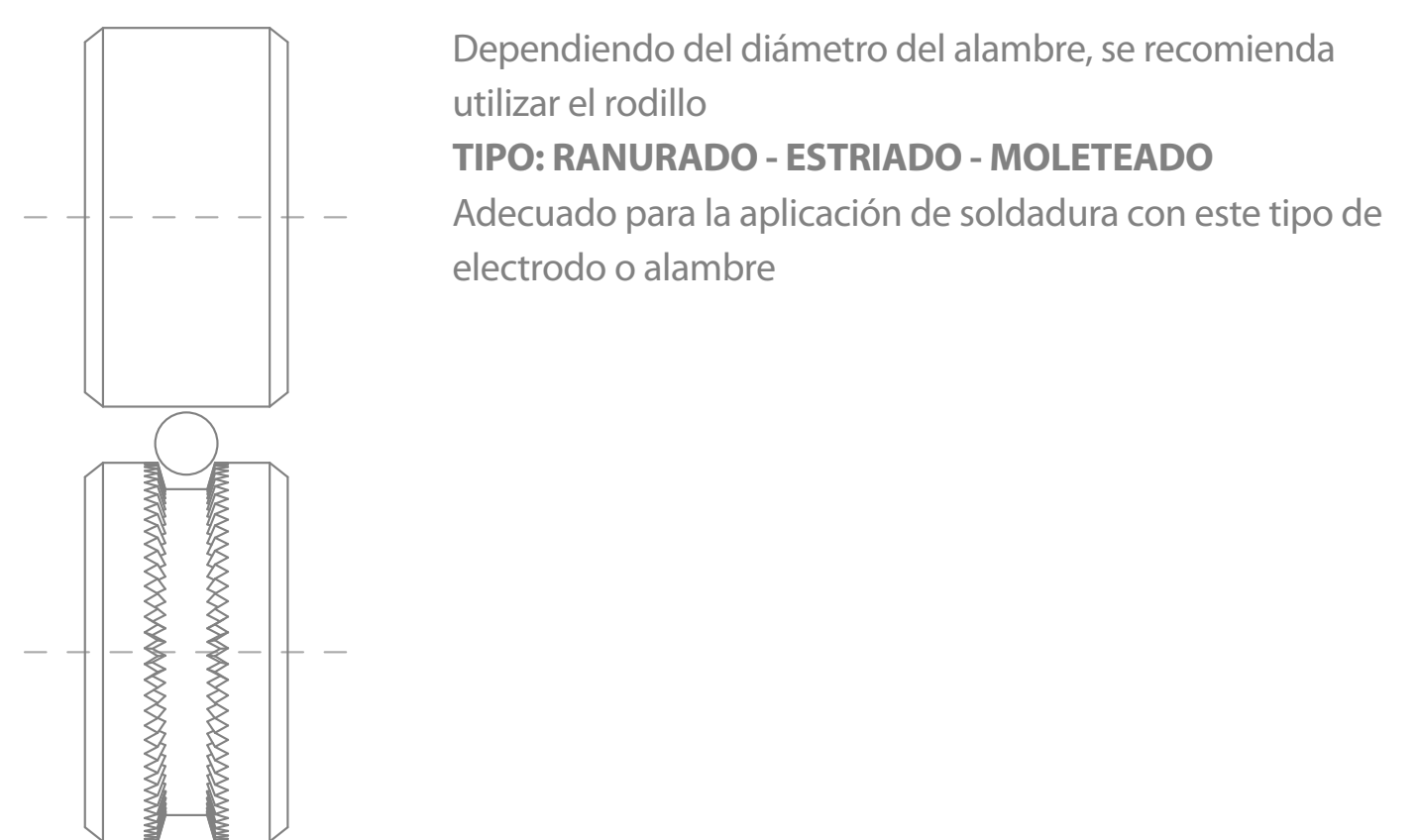

**MEDIDAS CAJA INDIVIDUAL**

Largo	<b>10.5 cm</b>
Ancho	<b>10.5 cm</b>
Alto	<b>5.0 cm</b>



CONOCE MÁS

