

Pb Free Plating Product

F60UP30DN



60Amperes,300Volts Dual Common Cathode Ultra Fast Recovery Rectifiers

APPLICATION

- Freewheeling, Snubber, Clamp
- Inversion Welder
- PFC
- Plating Power Supply
- Ultrasonic Cleaner and Welder
- Converter & Chopper
- UPS

PRODUCT FEATURE

- Ultrafast Recovery Time
- Soft Recovery Characteristics
- Low Recovery Loss
- Low Forward Voltage
- High Surge Current Capability
- Low Leakage Current

TO-3PB(TO-3PN)

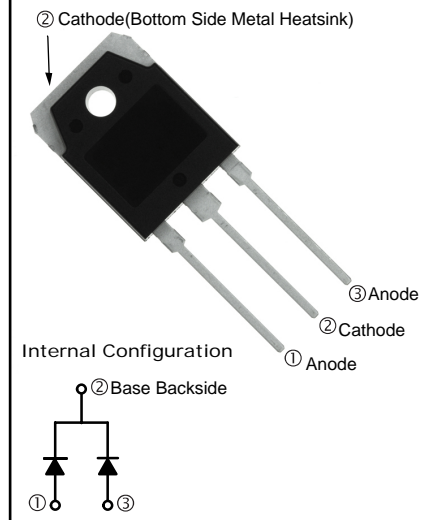

GENERAL DESCRIPTION

F60UP30DN using the latest FRED FAB process(planar passivation chip) with ultrafast and soft recovery characteristic.

Absolute Maximum Ratings				
Parameter	Symbol	Test Conditions	Values	Units
Repetitive peak reverse voltage	V_{RRM}		300	V
Continuous forward current	$I_{F(AV)}$	$T_c = 110^\circ\text{C}$	60	A
Single pulse forward current	I_{FSM}	$T_c = 25^\circ\text{C}$	600	
Maximum repetitive forward current	I_{FRM}	Square wave, 20kHz	150	
Operating junction	T_j		175	$^\circ\text{C}$
Storage temperatures	T_{stg}		-55 to +175	$^\circ\text{C}$

Electrical characteristics ($T_a=25^\circ\text{C}$ unless otherwise specified)						
Parameter	Symbol	Test Conditions	Min	Typ.	Max.	Units
Breakdown voltage Blocking voltage	V_{BR}, V_R	$I_R=100\mu\text{A}$	300			V
Forward voltage (Per Diode)	V_F	$I_F=30\text{A}$ $I_F=30\text{A}, T_j=125^\circ\text{C}$		0.96 0.85	1.20 1.00	
Reverse leakage current(Per Diode)	I_R	$V_R=V_{RRM}$ $T_j=150^\circ\text{C}, V_R=300\text{V}$			10 100	μA
Reverse recovery time(Per Diode)	t_{rr}	$I_F=0.5\text{A}, I_R=1\text{A}, I_{RR}=0.25\text{A}$ $I_F=1\text{A}, V_R=30\text{V}, di/dt=200\text{A}/\mu\text{s}$		35 26	45 40	ns

Thermal characteristics

Paramter	Symbol	Typ	Units
Junction-to-Case	$R_{\theta JC}$	0.8	$^\circ\text{C}/\text{W}$

Electrical performance (typical)

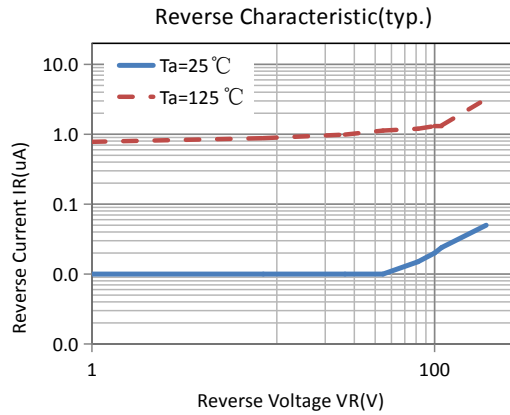
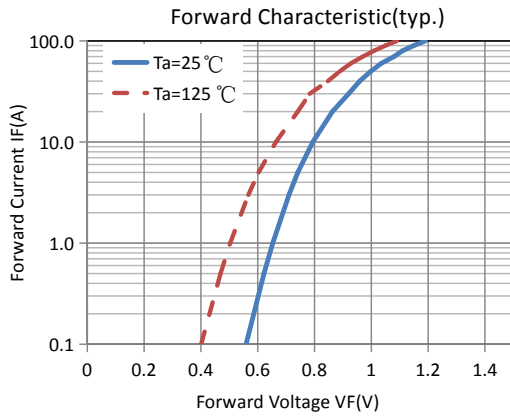

Package Information

TO-3PB PACKAGE

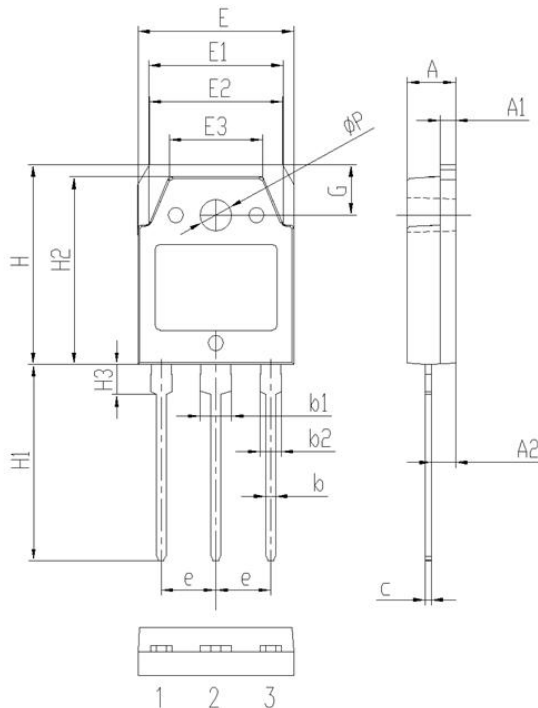

Symbol	Dimensions (millimeters)	
	Min.	Max.
A	4.60	5.00
A1	1.30	1.70
A2	2.20	2.60
b	0.80	1.20
b1	2.90	3.30
b2	1.90	2.30
c	0.40	0.80
e	5.25	5.65
E	15.3	15.7
E1	13.2	13.6
E2	13.1	13.5
E3	9.10	9.50
H	19.7	20.1
H1	19.1	20.1
H2	18.3	18.7
H3	2.80	3.20
G	4.80	5.20
ΦP	3.00	3.40